



Built-in 32.768 kHz-DTCXO, High Stability SERIAL-INTERFACE REAL TIME CLOCK MODULE

RX-4801 SA/ JE

- Built in frequency adjusted 32.768 kHz crystal unit and DTCXO.
- Interface Type : 4-wire serial interface
- Interface voltage range : 1.6 V to 5.5 V
- Temp. compensated voltage range: 2.2 V to 5.5 V
- Wide Timekeeper voltage range : 1.6 V to 5.5 V
- 32.768 kHz frequency output function : C-MOS output With Control Pin
- The various functions include full calendar, alarm, timer.



Product Number (Please contact us)
 RX-4801SA : X1B000021xxxx00
 RX-4801JE : X1B000041xxxx00

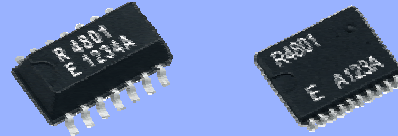

Actual size

RX-4801SA

RX-4801JE



Block diagram

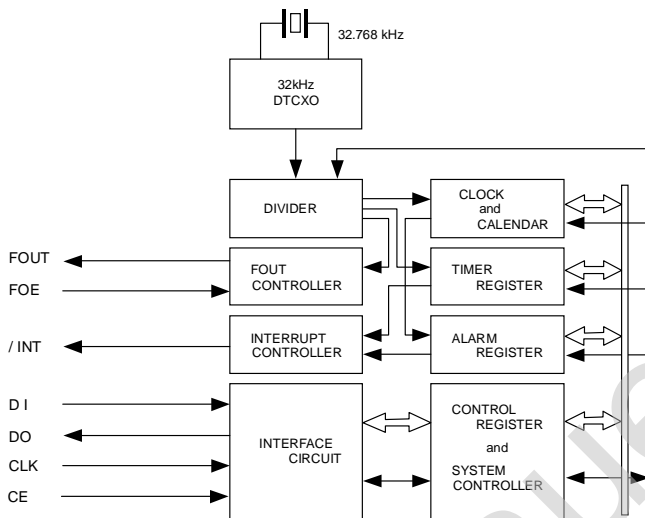

Overview

- High Stability
 - UA
 - ± 1.9 × 10⁻⁶ / 0 °C to +40 °C
(Equivalent to 5 seconds of month deviation)
 - ± 3.4 × 10⁻⁶ / -40 °C to +85 °C
(Equivalent to 9 seconds of month deviation)
 - UB
 - ± 3.8 × 10⁻⁶ / 0 °C to +50 °C
(Equivalent to 10 seconds of month deviation)
 - ± 5.0 × 10⁻⁶ / -40 °C to +85 °C
(Equivalent to 13 seconds of month deviation)
- 32.768 kHz frequency output function
 - FOUT pin output (C-MOS output), CL=30 pF
 - Output selectable
< 32.768 kHz, 1024 Hz, 1 Hz >
- The various interrupt
 - Timer Function can be set up between 1/4096 second and 255 minutes.
 - Alarm Function can be set to day of week, day, hour, or minute.

*It is possible to use it by the terminal connection as 32.768 kHz-DTCXO.

Pin Function

Signal Name	I / O	Function
/ INT	Output	The open drain output for interrupt.
GND	-	Connected to a ground
T2(Vpp)	-	* Use by the manufacture for testing. (Do not connect externally.)
DO	Output	The data output pin for serial data transfer.
DI	input	The data input pin for serial data transfer.
CE	input	The chip enable input pin.
CLK	input	The shift clock input pin for serial data transfer.
FOUT	Output	The pin outputs the reference clock signal. (CMOS output)
FOE	input	The input pin for the FOUT output control.
VDD	-	Connected to a positive power supply

Terminal connection / External dimensions

(Unit:mm)

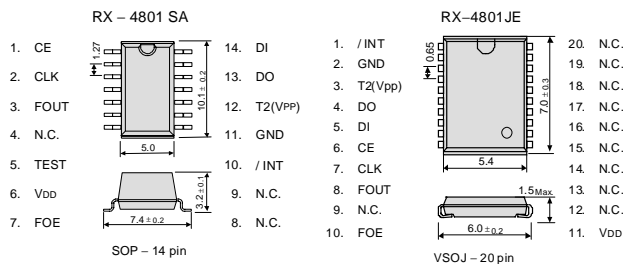

Metal may be exposed on the top or bottom of this product. This will not affect any quality, reliability or electrical spec.

Specifications (characteristics)

* Refer to application manual for details.

Electrical Characteristics

Item	Symbol	Condition	Min.	Typ.	Max.	Unit	
Interface voltage	V _{DD}	Interface voltage	1.6	3.0	5.5	V	
Temp. compensated Voltage	V _{TEM}	Temp. compensated voltage	2.2	3.0	5.5	V	
Clock voltage	V _{CLK}	-	1.6	3.0	5.5	V	
Operating temperature	T _{OPR}	-	-40	+25	+85	°C	
Stability	Δf/f	UA	T _a = 0 °C to +40 °C	±1.9 ^{*1}		× 10 ⁻⁶	
			T _a = -40 °C to +85 °C	±3.4 ^{*2}			
		UB	T _a = 0 °C to +50 °C	±3.8 ^{*3}			
			T _a = -40 °C to +85 °C	±5.0 ^{*4}			
Current consumption (1)	I _{BK1}	Backup Mode FOE = GND, /INT = V _{DD} FOUT output : OFF	V _{DD} = 5V	-	1.2	3.4	μA
Current consumption (2)	I _{BK2}		V _{DD} = 3V	-	0.8	2.1	μA

^{*1}) Equivalent to 5 seconds of month deviation. ^{*2}) Equivalent to 9 seconds of month deviation.
^{*3}) Equivalent to 10 seconds of month deviation. ^{*4}) Equivalent to 13 seconds of month deviation.

32.768 kHz-DTCXO Frequency temperature characteristics (Example)

